

# JBC

[www.jbctools.com](http://www.jbctools.com)



## Junior Tip Cleaner

Ref. CLMS-B

# Packing List

The following items should be included:

**Junior Tip Cleaner** ..... 1 unit  
Ref. CLMS-B

**CLMS Metal Brushes** ..... 1 unit  
Ref. CLMS-A8



**AC Adapter** ..... 1 unit  
Ref. 0015971

**Manual** ..... 1 unit  
Ref. 0017509



EU



US



## Operation & Features

The CLMS-B consists of 2 motorized brushes that are activated by pressing the button at the opening.

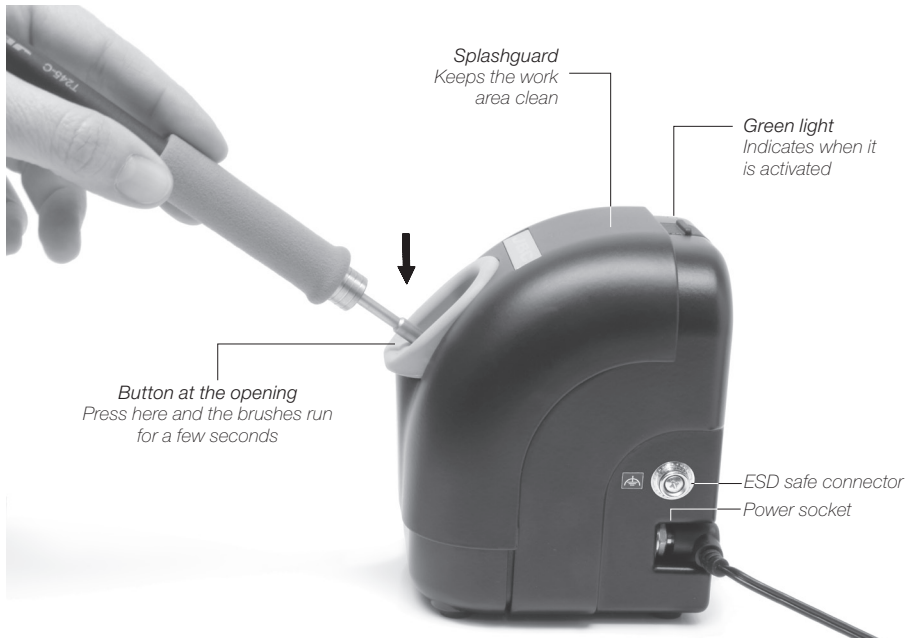

For the best uniform cleaning, place the tip between the 2 brushes and turn it for at least 1 second.

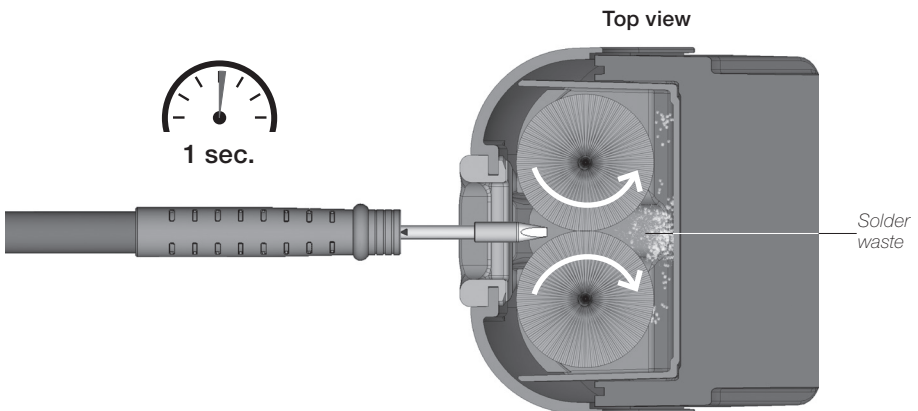

## Continuous mode

The tip cleaner has a second operating mode whereby the brushes run continuously.

**Bottom view**



**Switch ON/OFF**

Turn the switch to OFF and the brushes are activated in continuous mode.

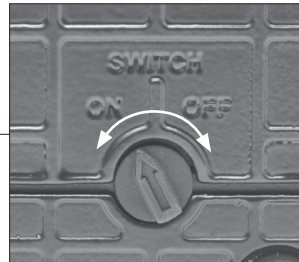

## Changing brushes and cleaning

Replace the brushes easily and clean the solder collector tray as follows:

**1. Opening the splashguard**



Unplug from the mains and press the tab at the top to open the splashguard.

**2. Removing the brushes**



Remove by pulling out the brush at the bottom end.

**3. Removing the solder collector tray**



Once cleaned, return the tray followed by the brushes.

## Changing Gate Protector

Easily replace the **Gate Protector**  
(Ref. 0015972) as follows:



### 1. Opening



Unplug from the mains and slide the tab on the top to open the splashguard.

### 2. Removing



Pull out the damaged gate protector.

### 3. Inserting



Insert the new one and when the tabs are positioned pull them to secure the gate protector in place.

### 4. Pressing into place

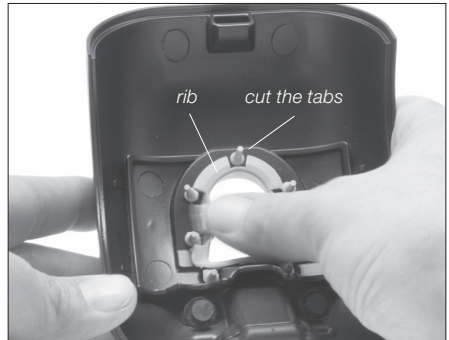

Once in place, cut off the tabs to avoid contact with the brushes.

## Maintenance

Before carrying out maintenance or storage, always unplug the equipment from the mains.

- Use a damp cloth to clean the splashguard and the inside.
- Keep the brushes and the tray clean and replace when necessary.
- Replace any defective or damaged parts. Use original JBC spare parts only.
- Repairs should be performed only by a JBC authorized technical service.

## Safety



**It is imperative to follow safety guidelines to prevent electric shock, injury, fire or explosion.**

- Do not use the appliance for any purpose other than tip cleaning. It is not a tool stand.
- The AC Adapter power supply must be plugged into approved bases. Be sure that it is properly grounded before use. Remove it by pulling the plug, not the wire.
- Do not leave the appliance unattended when on.
- Avoid contact when brushes are turning.
- Keep your workplace clean and tidy. Wear protective glasses and gloves to avoid personal harm.
- Utmost care must be taken with liquid tin waste which can cause burns.
- This appliance can be used by children over the age of eight and also persons with reduced physical, sensory or mental capabilities or lack of experience provided that they have been given adequate supervision or instruction concerning use of the appliance and understand the hazards involved. Children must not play with the appliance.
- Maintenance must not be carried out by children unless supervised.

## Exploded View

### CLMS-A

#### JUNIOR TIP CLEANER

#### SPARE PARTS

**CLMS-A:**

- METAL BRUSHES	CLMS-A8
- AC ADAPTER	0015971
- GATE PROTECTOR	0015972



# Specifications

- Weight: 1.45 kg (3.2 lb)
- Dimensions: 91 x 95 x 114 mm
- Brush diameter: 34 mm
- Brush speed: 550 rpm
- AC Adapter: Input: 96 - 264 V, 50Hz  
Output: DC 12V, 1A
- ESD safe connector

Complies with CE standards.  
ESD protected housing "skin effect".



## Warranty

JBC's 2 year warranty covers this equipment against all manufacturing defects, including the replacement of defective parts and labour.

Warranty does not cover product wear or misuse.

In order for the warranty to be valid, equipment must be returned, postage paid, to the dealer where it was purchased.



This product should not be thrown in the garbage.

In accordance with the European directive 2002/96/EC, electronic equipment at the end of their life must be collected and returned to an authorized recycling facility.



Manual in other languages available on our website

[www.jbctools.com](http://www.jbctools.com)